

# RECASH

## Cash Management System

CTS presents a new, complete, family of recycling products both for banknotes and coins that offer outstanding quality, functionalities, operability and reliability, suitable for any Point Of Sales application both attended or unattended.

Dedicated features meet the needs of businesses in a wide range of markets, including: supermarket, small shops, transport companies, post offices, banks and for all those who wish to simplify, optimize and secure coins and banknotes based cash payments in their daily operations.

The units can perform counting, validation and sorting of incoming coins and banknotes, of all the denominations, and can then recycle them to dispense change.

It is possible to combine the two recycler devices in order to create a solution that can easily handle any kind of cash payments.

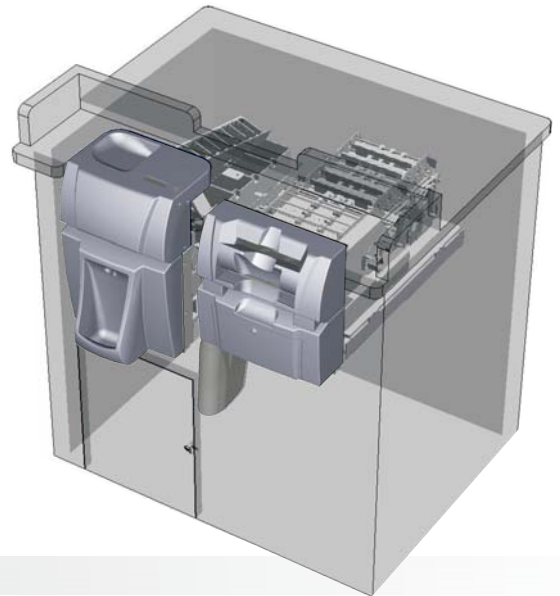

### CSD8 II - Technical data



- Entrance pocket capacity: up to 50 coins (mixed denominations).
- Reject / dispense pocket.
- Automatic detection and reject of foreign object (object and liquid rejection).
- A dedicated output bin is designed to empty the hoppers in bags to simplify the coins transportation and to manage the overflow.
- 8 denominations hoppers (up to 450 2€ or 1500 1cent).
- Validation, counting and deposit speed: up to 10 coin/sec.
- Dispensing speed: single hopper dispensing up to 6 coin/sec; multiple hopper dispensing up to 12 coin/sec.
- LCD console (show all relevant operating information, as the amount and quantity of coins present, chased and dispensed).
- Unit dimensions: length: 810 mm, width 300mm, height 460mm
- Communication: USB 2.0 / Rs232

### DBH-60 Technical data

- Entrance pocket capacity : Up to 50 banknotes (mixed denominations).
- Reject/output bin capacity: 20 banknotes
- Validation and deposit speed: up to 60 banknotes/minute.
- 2 recycling drawers
- Drawers size: 150 banknotes in good conditions.
- Not recyclable banknotes drawer: to be defined the dimension.
- Output speed: over 60 banknotes a minute.
- Unit dimensions with 2 drawers: length: 700 mm, width 320 mm, height 300 mm.
- Two extra drawers dimension: extra length 270 mm.
- Communication: USB 2.0

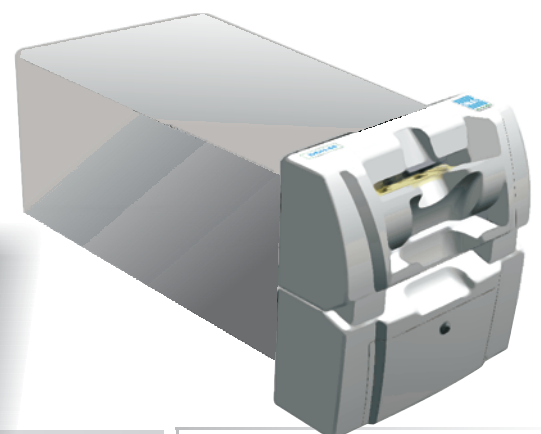

10015 Ivrea (TO) - ITALY  
Corso Vercelli, 332  
Call. ++39-0125-235611  
Fax. ++ 39-0125-235623  
e-mail: sales@ctsgroup.it  
www.ctsgroup.it